



---

# ***R series***

**WOOD CHIPPER**

*User's Manual*

**5/5L/6/8/8L**



## CONTENT

2. SAFETY .....	1
2.1. GENERAL SECURITY .....	1
2.2. PERSONAL PROTECTION .....	1
2.3. ENVIROMENT SECURITY .....	1
2.4. ENGINE SECURITY .....	2
2.5. MACHINE SECURITY .....	2
3. SECURITY STICKERS .....	2
4. UNPACKING .....	3
4.1. ASSEMBLY .....	4
4.1.1 Machine assembly of model 4/6/8 .....	4
4.2. FUEL AND OIL .....	5
5. STARTING .....	5
6. STARTING AND OPERATION .....	6
7. MAINTENANCE .....	7
7.1. CLEANING .....	7
7.2. BELT ADJUSTMENT AND REPLACEMENT .....	8
7.3. LUBRICANT AND GREASE .....	8
7.4. BLADE AND ANVIL .....	8
8. PROBLEMS, REASONS AND SOLUTIONS .....	9
10. TRANSPORT .....	10
11. STORAGE .....	10
12. INFORMATION OF RECYCLING/ENVIROMENTAL PROTECTION .....	11

## 2. SAFETY

These chippers are designed to chip wood with chip capacity up to 40mm -80mm at maximum (according to model respectively).

No input of any material which is not allowed, such as metal, stone, plastic, fabric or any wood branch with diameter over the maximum size, as they can seriously damage the machine or cause injure to operator or the third party or things. Please have the manual and all signs in good condition for future use. When you sell the machine, make sure you have all instructions material passed to the new owner.

Remember the operator is responsible for any accident caused by improper use of the machine. This manual contains all necessary instructions which are related to personal safety and that of others, animals around. if you have any questions about safety instructions in this manual, kindly contact professional service or ask for help from the shop authorized to solve it.

### 2.1. GENERAL SECURITY

This machine has been designed to be used by an adult who has read and understood the manual and has been trained to know all security rules. Children, people with mental or psychological problem or anyone who is lack of info about this machine are NOT allowed to use this machine.

Before using the machine, make sure you know how to use them, where all control parts and devices are, and know Chip system of this machine is very sharp.

To the first-time user, we strongly recommend that a practice with pieces of wood should be processed if possible, with company of experienced user.

Before working, mark an area with 3 meters wide and 12 meters long on the output side.

Make sure no one could get injured by the wood chips flying out during working, make sure no one is around with radius of 12 meters

*\*Suggestion\**

*To mark the area by yellow, or red and white beacon.*

### 2.2. PERSONAL PROTECTION

Be careful of what you are doing and use common sense to operate it.

Do not use this machine while tired or under the influence of alcohol, drugs or medication. A moment of inattention, serious injuries to people or damage to machine could occur.

Any tools or parts left on or in the machine, can cause serious damage to the machine, or injure to people around. Clear up the surroundings and remove all tools around the machine.

Always use personal safety equipment, such as, goggle, earmuff and gloves. The machine is working with noise over 90dB; ear muffler is a must while working with the machine. If ear is not protected, long time working noise could affect user's listening ability.

Do not wear loose clothing or ties during working.

Make sure the machine is well balanced and stand firmly on ground all the times.

### 2.3. ENVIROMENT SECURITY

Do not use this machine in an explosive place or nearby flammable liquid, gas or dust. Suggest using the machine outdoor only.

Do not go back to work only if the place is fully refreshed.

If you must use it indoor, make sure you keep the place very well ventilated.

Do not use the machine at night, in a foggy day or any situation with less visibility. Clear up the working area, and work with good lighting

When the machine is operated by two persons at the same time, make sure the position of another person is safe, before you start the machine. Always check and confirm with your company before running the machine.

## 2.4. ENGINE SECURITY

## 2.5. MACHINE SECURITY

Failure to follow all instruction listed in this manual could cause serious problem

Remember the operator is responsible for any accident to himself, third party or things. Manufacturer is not responsible for injuring or damage caused by improper use of the machine.

Before use of the machine, always check:

If any screw or bolts are loose.

If the rubber curtain is broken.

If there is damage to machine body, broken parts.

(Replace it if it is damaged or worn)

if the oil is enough

If the wires are good.

If blade is sharp enough

Always make sure all misalignment, loose parts or breakage are fixed and repaired before machine started.

Make sure the machine is in good maintenance by professionals from authorized dealers.

Manufacturer disclaims the responsibility for any damage caused by non-original parts, defective parts or worn parts.

Any adjustments, refuel, nozzle fixing, transport, or storage, are made, please recheck the machine.

All preventive maintenance can reduce the risk to meet the machine problem. Do not leave the running machine alone.

Reduce the speed of engine, before you shut off completely.

Sudden stop is recommended to be used only under emergency.

Replace the sticker if it is broken or not sufficient legible.

Do not move or tilt the machine while machine is running.

*Periodically maintain your machine through authorized dealers or shops. Using the original parts from authorized dealers or shops could ensure the safety of your machine.*

## 3. SECURITY STICKERS

All the following security stickers on the machine or in this manual indicate necessary information of safety, and the right way to use this machine.

	<p>Reminder of oil filling and oil refreshing.  <i>Change oil after 5 hours of first use.</i>  <i>Regularly change oil every 50 hours for normal use</i></p>		<p>Rotor with blades running inside. be caution that rotor full stopped before opening the hopper or output.</p>
<p><b>CAUTION</b></p> 	<p>Be caution of flying debris or chips out of conveyor. serious injuries could occur.</p> <p><b>Label for R8, R5 and R5e</b></p>		<p>Regularly lubricant bearings every 50 hours</p>
	<p>No overloading and No chipping branch over max capacity.</p>	<p><b>DANGER</b></p> 	<p>Do not try to put your hand or any part of your body into chipper.</p> <p><b>Label for R8L and R5L</b></p>
		<p>*Read and understand the manual before the operation.          *All labor protecting equipment should be worn properly.</p>	
			<p>*Standbys should keep safe distance from the running machine.          *Any maintenance should be proceed while machine fully stopped.          *NO debris left in rotor housing before engine shut down</p>
			<p>*Do not work inside house, keep good ventilation.          *No smoking and NO close to fire while working</p>
			<p>*No fuel refilling while engine is on.          *Be caution of hot surface around exhauster area          *Do not try to put your hand or any part of your body into chipper.</p>

#### 4. UNPACKING

Carefully remove the CARTON, check the machine thoroughly to ensure there is no damage,

missing parts or tools.

If there is damage, missing parts or tools, please contact the seller for a make-up, do not run the machine before they are fixed or repaired.

#### 4.1. ASSEMBLY

##### 4.1.1 Machine assembly of model 5/5L/6/8/8L

In the process of installation, do not touch the blades with your hands or any other body parts. Considering the heavy weight of the machine, do not try to install it by oneself in case of the possible injury.

All bolts, nuts and washers have been fixed on the machine in the factory, please remove them before assembly and put back on the machine at the same locations.

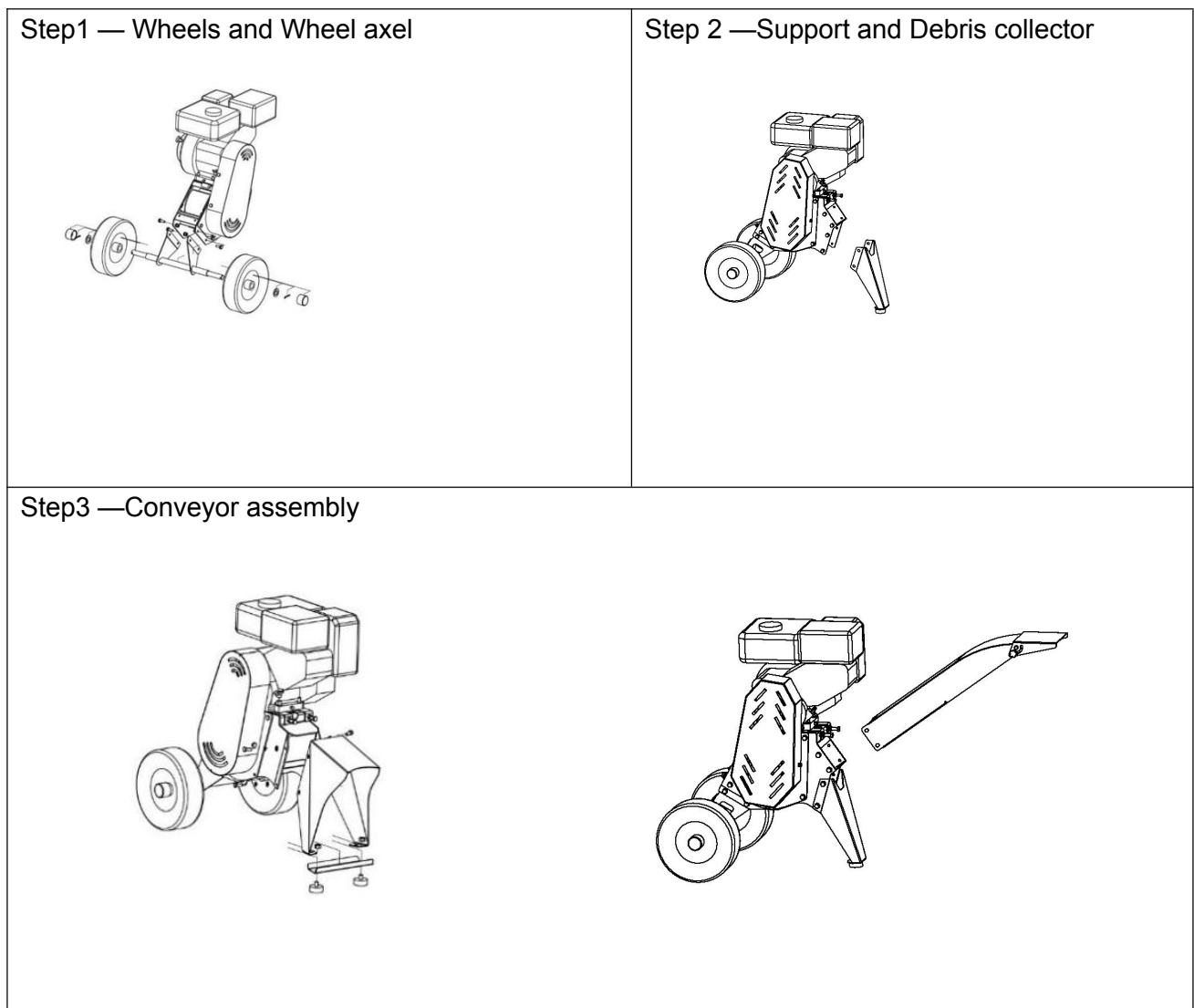

Step4 —Infeed hopper and handle

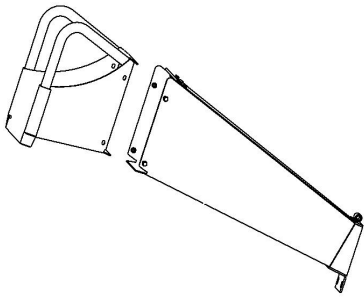

Step5 —Hopper Assembly

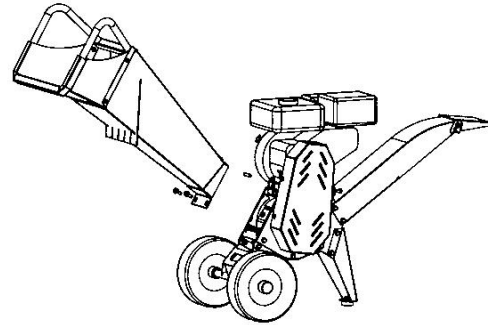

Step 6. – Connect the emergency cable. Fix the switch box by tightening the two bolts (A), and then connect the cable plug.

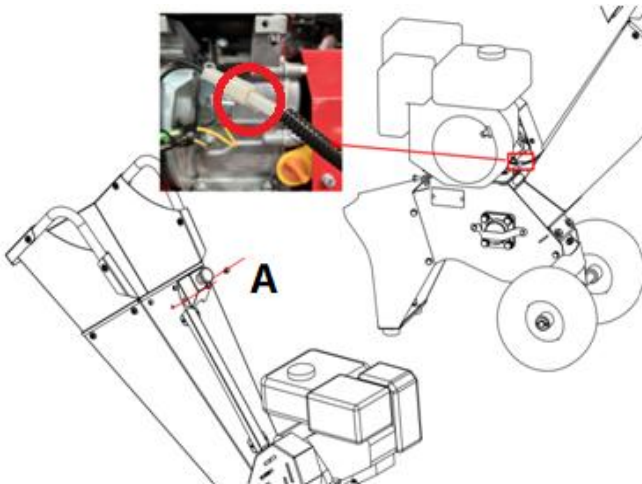

Step 8. – ATV tow bar assembly

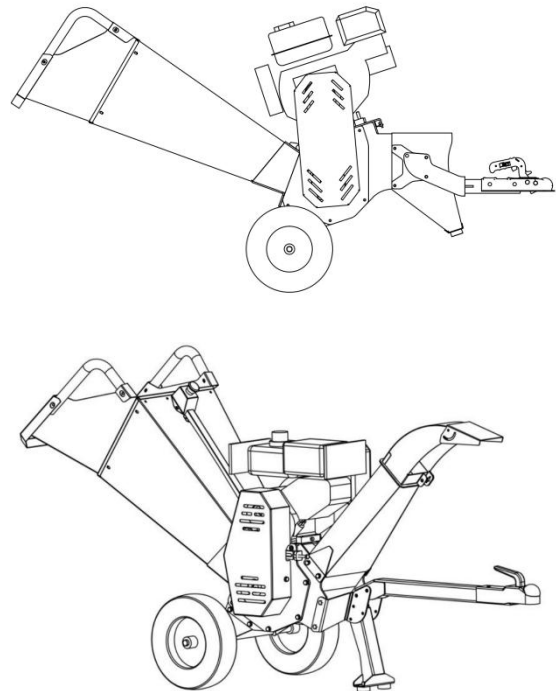

#### 4.2. FUEL AND OIL

\*PLEASE REFER TO ENGINE MANUAL CAREFULLY\*

#### 5. STARTING

\*Do follow the instructions as below\*



Bolts for blade and counter blade are tightened by torque wrench at torque of (60Nm for blade and 40Nm for counter blade).

Check the hopper before starting, to make sure there is nothing in it. If there is something, please clean it up by stick or reach tools.

Put your clothes, hands, limb away from hopper, rotor or any rotating parts.

Stay away from conveyor side before starting

Stand on your feet in balance.

It is obligatory to wear safety gloves, earmuff and safety goggles.

Please do not use this machine where the exhaust fumes might collect.

This machine should be used by one, preferably the same person only.

This machine is designed to be used in an open air.

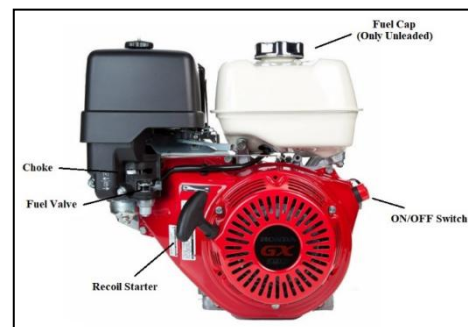

## 6. STARTING AND OPERATION

The hardness of the wood depends on the wood type, the time between pruning and chipping and how dry the branches are. This machine performs best if the branches are chipped right after pruned.

To start the machine

Emergency switch is pop-up

Engine switch is of 'on' position

Fuel supply is open

Open Air intake to allow fresh air

Slowly pull the recoil rope 3-5 times to get fuel supply system filled

Then pull with strength till engine is fired

Keep engine running at idle speed for 1 minutes

Slowly push the throttle bar to the 'Rabbit'

Keep the engine at full RPM (revolution per minute) while working to protect machine from clogging.

### \*NOTE\*

This machine is only for the use that has been designed. To use it for other purpose may cause injure to people or damage to machine.

Put the branches into the hopper and when they are pulled in and let them go. The branches will be pulled in automatically.

While chip thick ones, pay attention the engine and keep it maintained.

Trim the side branch over 3cm in diameter, before put it into hopper separately. Long branches and thick branches will shake and might slash into your face, make sure you hold it firmly and always wear the face protection.

TO STOP MACHINE:

Use the emergency switch immediately if there is urgency.

Normally, the engine should be allowed to idle status by turning to(TURTLE) first for a minute then switch off the engine

If you want to stop chipping let the machine run for a while, to chip and eject all debris left which could jam the rotor while you want to start the machine next time.

#### MACHINE GET JAMMED

If the machine gets stuck by pieces of input. do as follow:

Stop the machine, disassemble the plastic bearing cover, and turn the rotor a few degrees by rotor spanner specially made.

If piece of wood in the hopper lying crosswise. It can only be removed when the machine is fully stopped.

DO NOT PUT YOUR HAND ON THE ROTOR.

Check machine after work, to ensure all bolts, nuts and screws are tight. If not, tighten them

## 7. MAINTENANCE

### \*WARNING\*

Before any performance of maintenance or repairing, make sure the engine is fully stopped. and spark plug is removed.

Regularly do the maintenance to ensure the effective performance of the machine. For a seasonal check and maintenance, we strongly recommend doing it through the service by dealer authorized. Removal of safety devices, replacement of parts with non-original ones, improper maintenance can cause injure to people and damage to the machine

Do not adjust the carburetor, as the adjustment of carburetor is complicated. We suggest to do that adjustment by the professional service of dealer authorized. Wrong adjustment of carburetor could damage the engine and make the warranty voided.

It is always necessary to stop the machine before any clean or transport work. Maintenance should be done in a flat, clean area.

### 7.1. CLEANING

Using high pressure air flow to clean debris left in Rotor box, on surface of machine (esp. on the engine)

Cylinder fins is the main way to cool the heat from working cylinder. So keep the fins clean and check it out regularly is very helpful to prevent over heating in the engine. Use the suitable tool to clean away the dirt, wood chips, earth and all possible thing that block the cooling process.

Clean electrical components with a damp rag, spray with WD40 and then wipe with dry rag.

## 7.2. BELT ADJUSTMENT AND REPLACEMENT

### 7.2.1 MODEL 6/8

- Remove the belt cover
- Loose the block nut (2) and lock bolts (3)
- Slightly turn adjust Thread rod (1) in to tighten belts
- Slightly turn adjust Thread rod (1) out to tighten belts
- Check if the pulleys are in line. You can see this by holding a bar against the pulleys
- You have reached the right tension when the belt can be pushed down by +/- 8 MM.
- Tighten the lock bolts and block nut, put back the belt cover

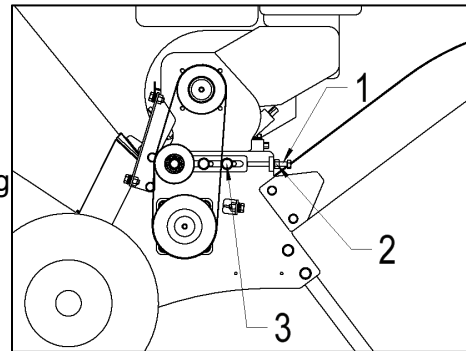

### 7.2.2 MODEL 5/5L/8L

To raise belt tension,

- Loose the nuts (3), then loose the nuts (1), there are 4 nuts front and back totally.
- Screw the bolts (4) in evenly, to pull the tension plate (2) out.
- Belt tension will be raised with the movement of engine.

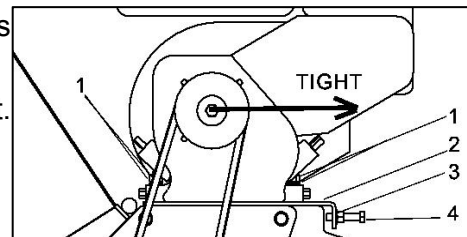

While you need to loosen belt tension, you can do it in return.

After adjustment, make sure you have all bolts and nuts in right position and tightened.

## 7.3. LUBRICANT AND GREASE

Grease / oil bearings daily before use.

Recommended Lubricants	Specifications
Grease	Complex grease EP2 - High temperature

## PARTS NEED GREASING

Rotor bearing

## 7.4. BLADE AND ANVIL

Blade are extremely sharp, take care please!

Blades and anvil need cleaning after every time chipping work, and protected from rusty corrosion

### 7.4.1 BLADE MOUNTING

Slacken blades bolts with Torx tool supplied and remove

Turn blades round and refit to use opposite edge

Clean the blade holder surface thoroughly

Tighten blade bolts to 60Nm from middle to both sides evenly

Check clearance to anvil is 0.5-1mm.

If blades have been reground the anvil will need readjusting to 0.5mm.

### 7.4.2 BLADE REGRINDING

Both edges of each blade must be ground on front at 30° angle and on back 5° angle over 2mm to ensure correct clearances.

Blades must only be sharpened by grinding on a bench grinder. Do not sharpen with hand held equipment. Always sharpen in sets to maintain balance of cutter assembly.

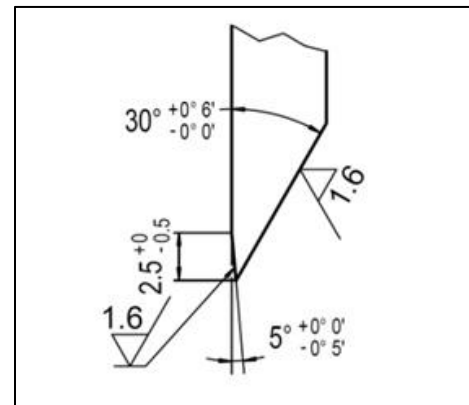

### 7.4.3 ANVIL SERVICING

Change side when the side edge on the tapered top gets round.

Change anvil when both sides get round.

\*Note\*

The anvil will need readjusting to 0.5mm.

**Perform maintenance periodically as following table:**

Maintenace	Every time	First 5 hours	Every 25 hours	Every 50 hours	Every 100 hours	First use of season	Last use of season
Grease parts	x						
Check oil level	x						
Change oil		x	x	x	x	x	
Empty oil and fuel							x
Clean air filter	x						x
Check spark plug				x		x	
Belt checking	x						
Blade checking	x						

## 8. PROBLEMS, REASONS AND SOLUTIONS

By the performance of machine, you see, you can detect the problem and find solution accordingly. Hereafter is a trouble shooting table, where you can find solution for possible problems:

Problem	Reason	Solution
---------	--------	----------

Machine cannot chip properly Rotor cannot pull branches Chips are not in similar size	Blade worn too much Oversize input Gap between blade and counter blade is not right	Reverse, sharpen or replace blade Take input out and make it right Right adjustment on counter blade
Engine cannot be started or stop by itself	Electricity line was loose or broken Oil level is not right No fuel, fuel supply was blocked	Check the switch and emergency switch is disabled Fill or drain oil to make it right (ref. 8.1.2) Check fuel tank and carburetor cup
Rotor get jammed	Material being chipped is not right Too much input	Ref. 6.3.2
Conveyor gets jammed	Too much wet, soft or light material	Disassemble the conveyor and take jam out.

Please refer to the trouble shooting table in the engine manual. **STRONGLY RECOMMEND TO REPAIR ENGINE AT SERVICE CENTRE**, if the engine is not working properly, such as lack of power, shaking at idle speed...

## 10. TRANSPORT

Do not carry and move the machine while it is still running. Always remember to stop the machine before you intend to move the machine.

Be caution that the muffler is still very hot even after the engine is turned off. So, keep the machine completely cool down.

Take a look at the weight of machine in this manual if you want to move it. It is better to be moved or transported by two people,

Transport by two people can reduce the risk of possible injure caused by heavy weight.

If it is carried by vehicle, make sure you have the machine firmly fixed to avoid sliding and tipping.

## 11. STORAGE

Make sure this machine is not accessible for children,

Never store this machine nearby flammable material such as, gas, fuel, dry grass, wood...etc., so that it cannot endanger any person.

Store this in a dry, well ventilated place with temperature between 0°C to 45°C.

**\*NOTE\***

If you are planning to store this machine for a while, please pay attention to the following points.

Cool the machine completely

Clean the machine thoroughly

Drain off all fuel and oil in the machine Waste fuel and oil should be dealt according to local recycling regulation.

## 12. INFORMATION OF RECYCLING/ENVIROMENTAL PROTECTION

It is obligatory for each people to protect our only earth, to protect our environment we are living around. Do not pour the waste fuel, oil or grease in to soil, river, lake and sea, always bring them to certain place authorized.

Package material of this machine, are recyclable, please do not dispose them together with household waste; put them to the official authorized site.



**JONCO**  
simple but different

FIND US ONLINE    